

Lilium GmbH

Claude-Dornier-Str. 1, Geb. 0101
82234 Wessling
Germany

Dirk Sessel



Customer

Project Description Unidirectional Power Supply & Eletronic Load
 Job Number PS For MSN 1 & 2
 Lilium Patrimony Number EL015

Manufacturer (company) Lilium eAircraft GmbH

Path

Project name Unidirectional Power Supply and Electronic Load
 Power supply
 Input Voltage 400 V
 Control voltage 24VDC
 Place of installation
 Responsible for project Matheus

Edit date 6/6/2024 by (short name) matheus.hagemann.ext Number of pages 25

			Date	5/24/2024	EL015		Cover		= Cover
			Ed.	MATHEUS HAGEMANN	Unidirectional Power Supply & Eletronic Load		Lilium eAircraft GmbH		+
Modification	Date	Name	Original	Replacement of	Replaced by			PS For MSN 1 & 2	Page 1 / 25

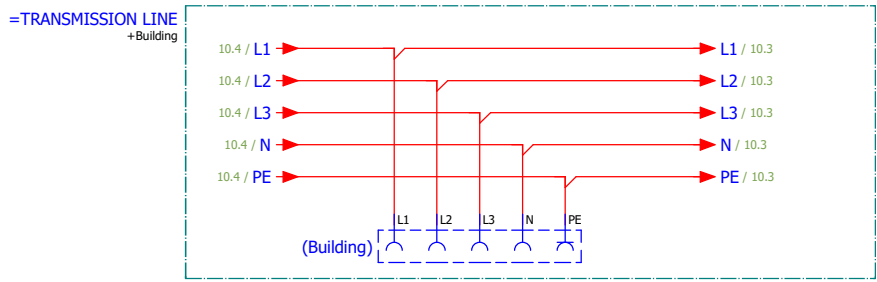

External Supply
Protection Required
Fuse/Circuit Breaker:
100A

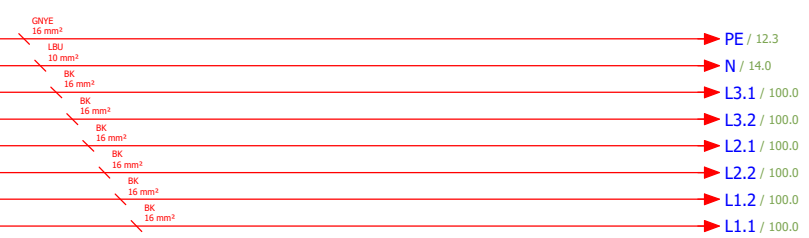
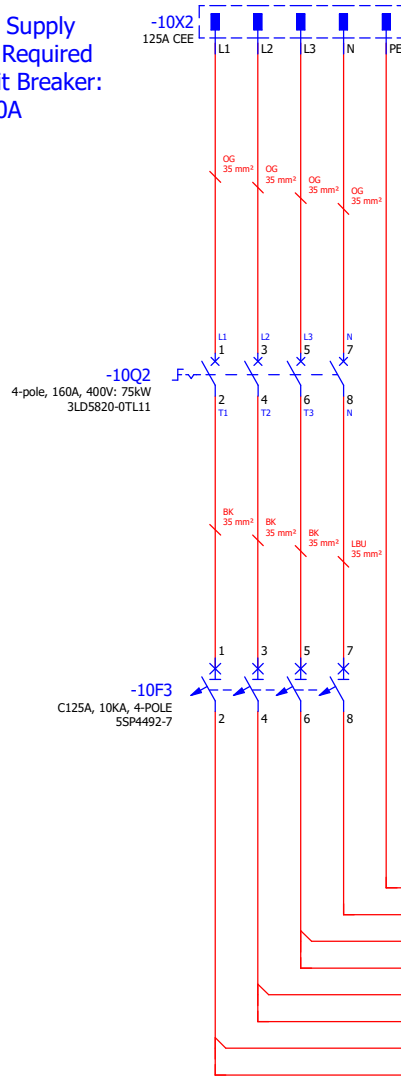

=Cover+/5

				Date	6/4/2024	EL015		Panel Feeding	Lilium eAircraft GmbH	= Main Enclosure	
				Ed.	matheus.hagemann.ext					+ E01	
				Appr.							
Modification	Date	Name	Original	Replacement of		Replaced by			PS For MSN 1 & 2	Page	10
										Page	5 / 25

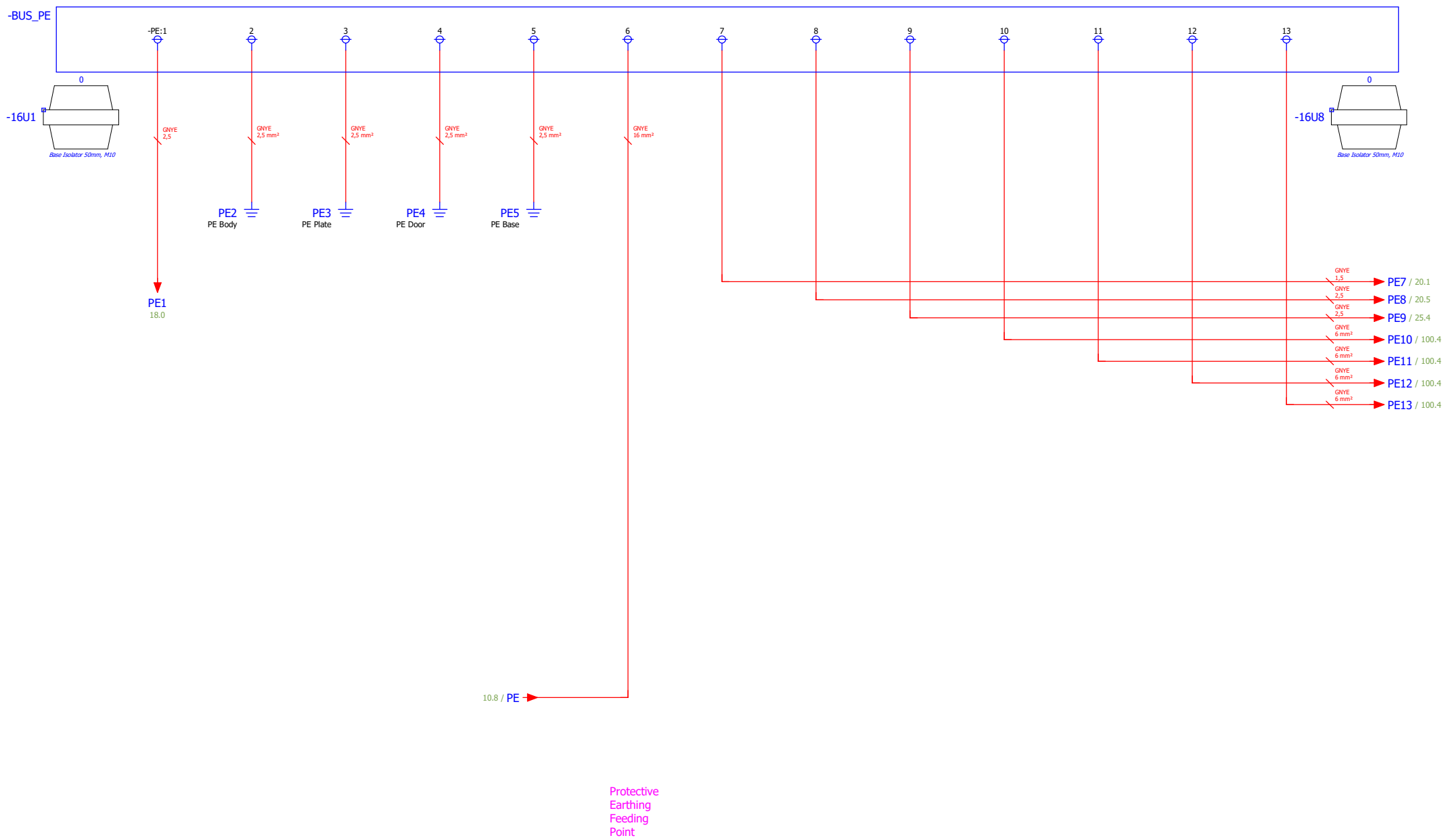

			Date	6/5/2024	EL015 Unidirectional Power Supply & Electronic Load		PE Distribution Lilium eAircraft GmbH	= Main Enclosure		
			Ed.	matheus.hagemann.ext				+ E01		
			Appr.					Page	12	
Modification	Date	Name	Original		Replacement of	Replaced by		PS For MSN 1 & 2	Page	6 / 25

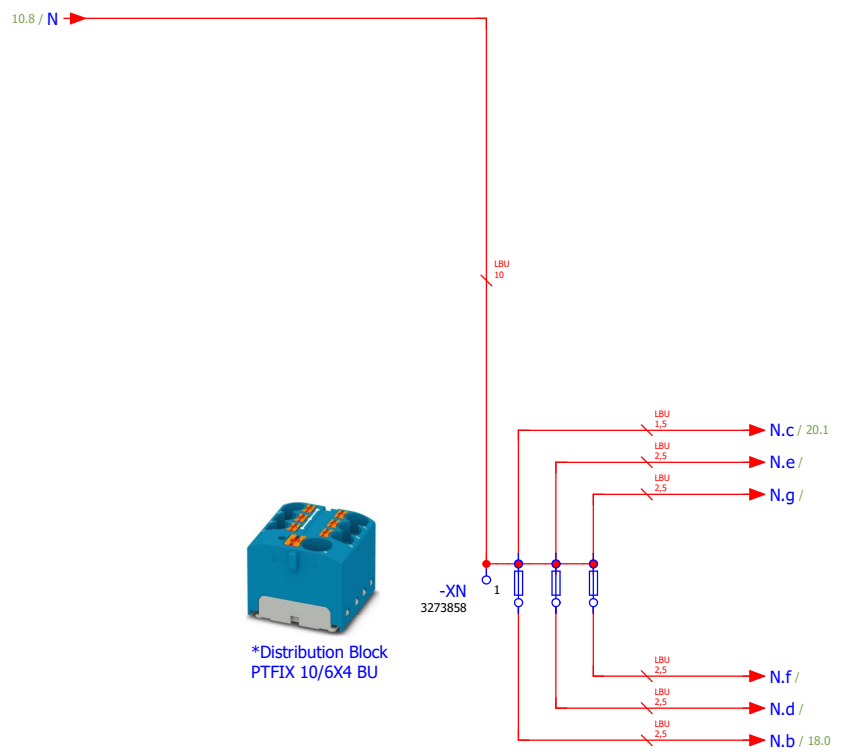

*Distribution Block
PTFIX 10/6X4 BU

			Date	6/4/2024	EL015		Neutral Distribution	Lilium eAircraft GmbH	= Main Enclosure	
			Ed.	matheus.hagemann.ext					+ E01	
			Appr.		Unidirectional Power Supply & Eletronic Load				PS For MSN 1 & 2	Page 14
Modification	Date	Name	Original		Replacement of	Replaced by				Page 7 / 25

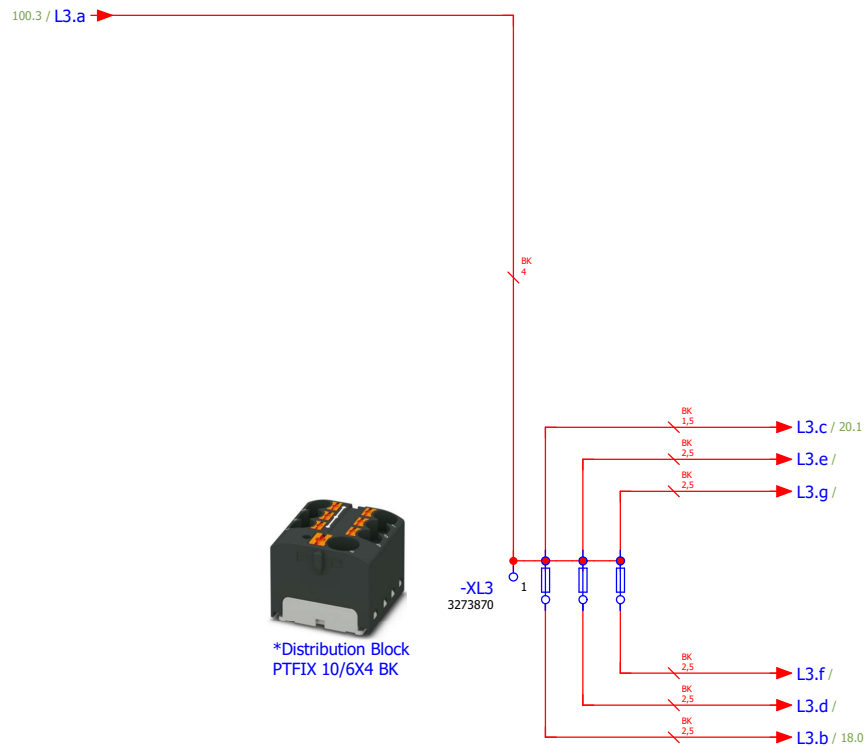

			Date	6/4/2024
			Ed.	matheus.hagemann.ext
			Appr.	
Modification	Date	Name	Original	

EL015	
Unidirectional Power Supply & Eletronic Load	
Replacement of	Replaced by



Line 3 Distribution
Lilium eAircraft GmbH

= Main Enclosure	
+ E01	
PS For MSN 1 & 2	Page 16
	Page 8 / 25

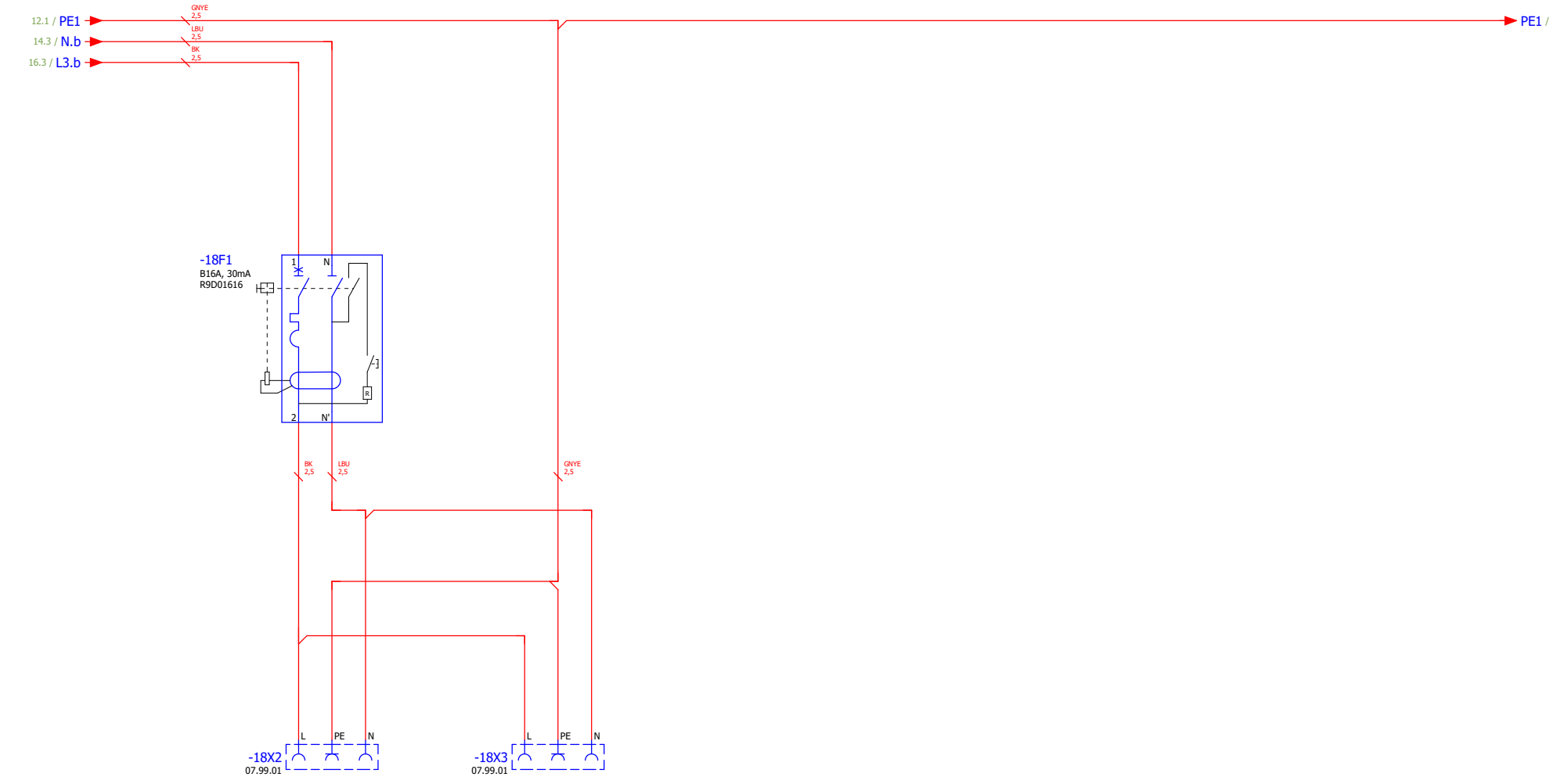

				Date	6/6/2024	EL015		Outlets		= Main Enclosure	
				Ed.	matheus.hagemann.ext			Lilium eAircraft GmbH		+ E01	
				Appr.							
				Original		Replacement of	Replaced by	PS For MSN 1 & 2		Page	18
Modification	Date	Name	Original							Page	9 / 25

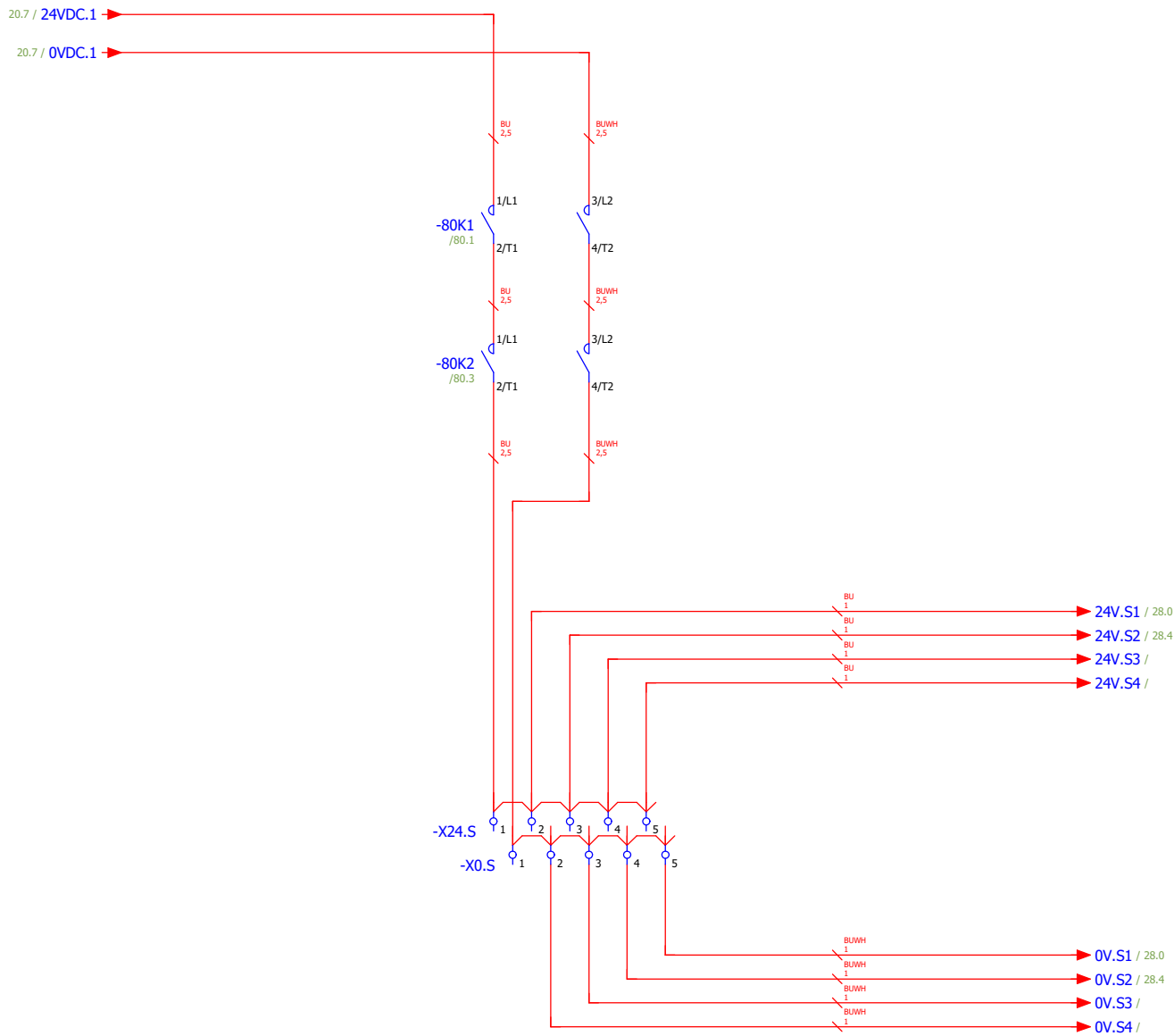

			Date	6/6/2024
			Ed.	matheus.hagemann.ext
			Appr.	
Modification	Date	Name	Original	

EL015	
Unidirectional Power Supply & Eletronic Load	
Replacement of	Replaced by



24V Safety
Lilium eAircraft GmbH

= Main Enclosure	
+ E01	
PS For MSN 1 & 2	

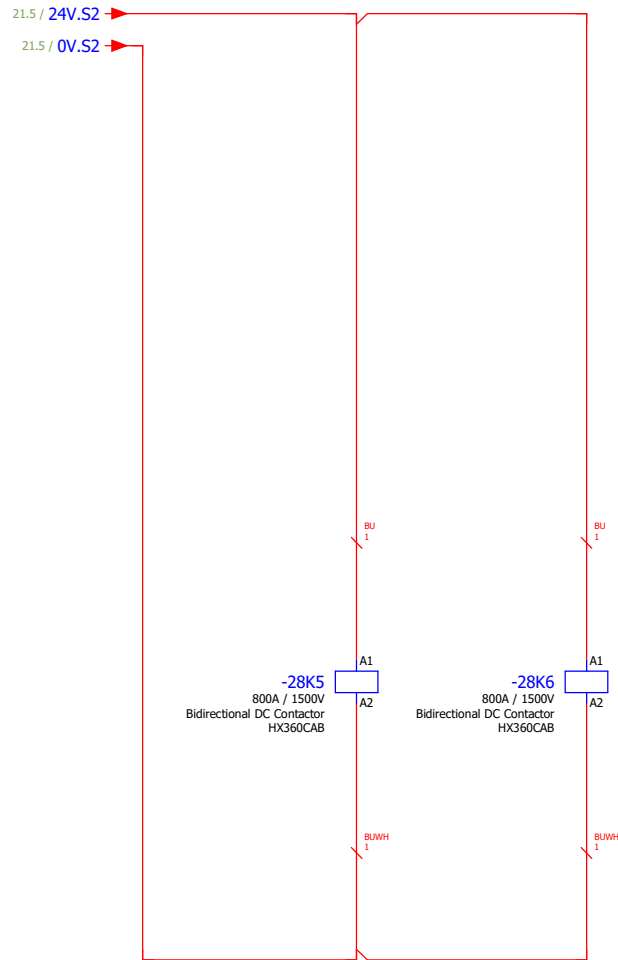
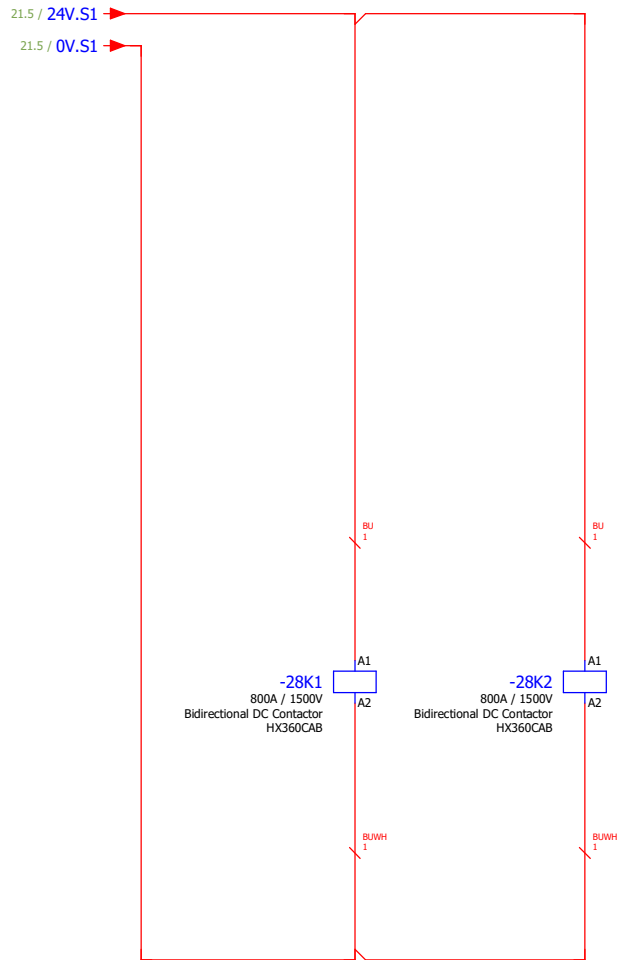

				Date	6/6/2024	EL015		DC Safety System - Coil		= Main Enclosure	
				Ed.	matheus.hagemann.ext	Unidirectional Power Supply & Eletronic Load		Lilium eAircraft GmbH		+ E01	
				Appr.		Replacement of		Replaced by		PS For MSN 1 & 2	
Modification	Date	Name	Original							Page	28
										Page	13 / 25



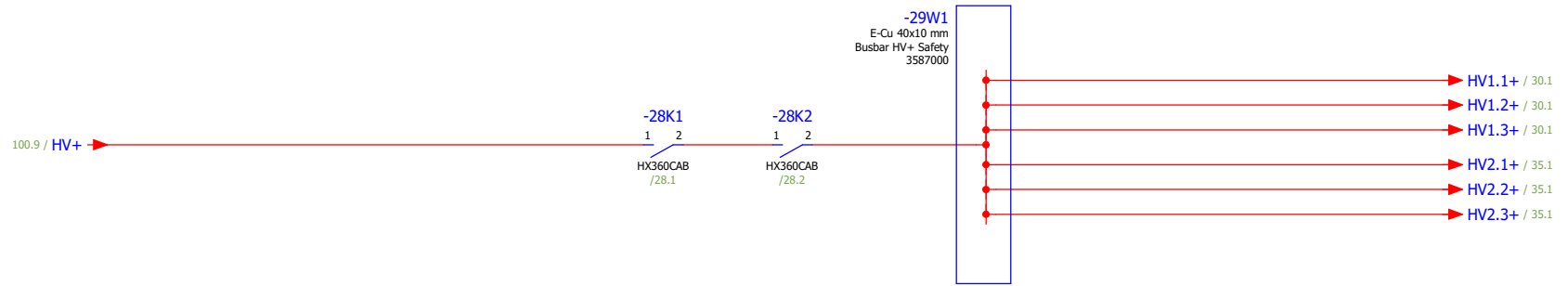

HX360CAB
Gigavac 800 Amp 1500 Vdc Contactor

- Robust High Voltage/High Power load break bi-directional DC contactor
- Excellent isolation performance: 10kv withstand between open contacts for critical safety applications
- Mechanically linked SPDT auxiliary contacts for critical safety applications.
- Reliable indication of the main contacts in the closed position
- Hermetically Sealed - Exceeds IP67-69 specifications. No exposed arcing to open air environments.

			Date	6/6/2024
			Ed.	matheus.hagemann.ext
			Appr.	
Modification	Date	Name	Original	

EL015	
Unidirectional Power Supply & Eletronic Load	
Replacement of	Replaced by



DC Safety System - Output
Lilium eAircraft GmbH

	= Main Enclosure
	+ E01
PS For MSN 1 & 2	

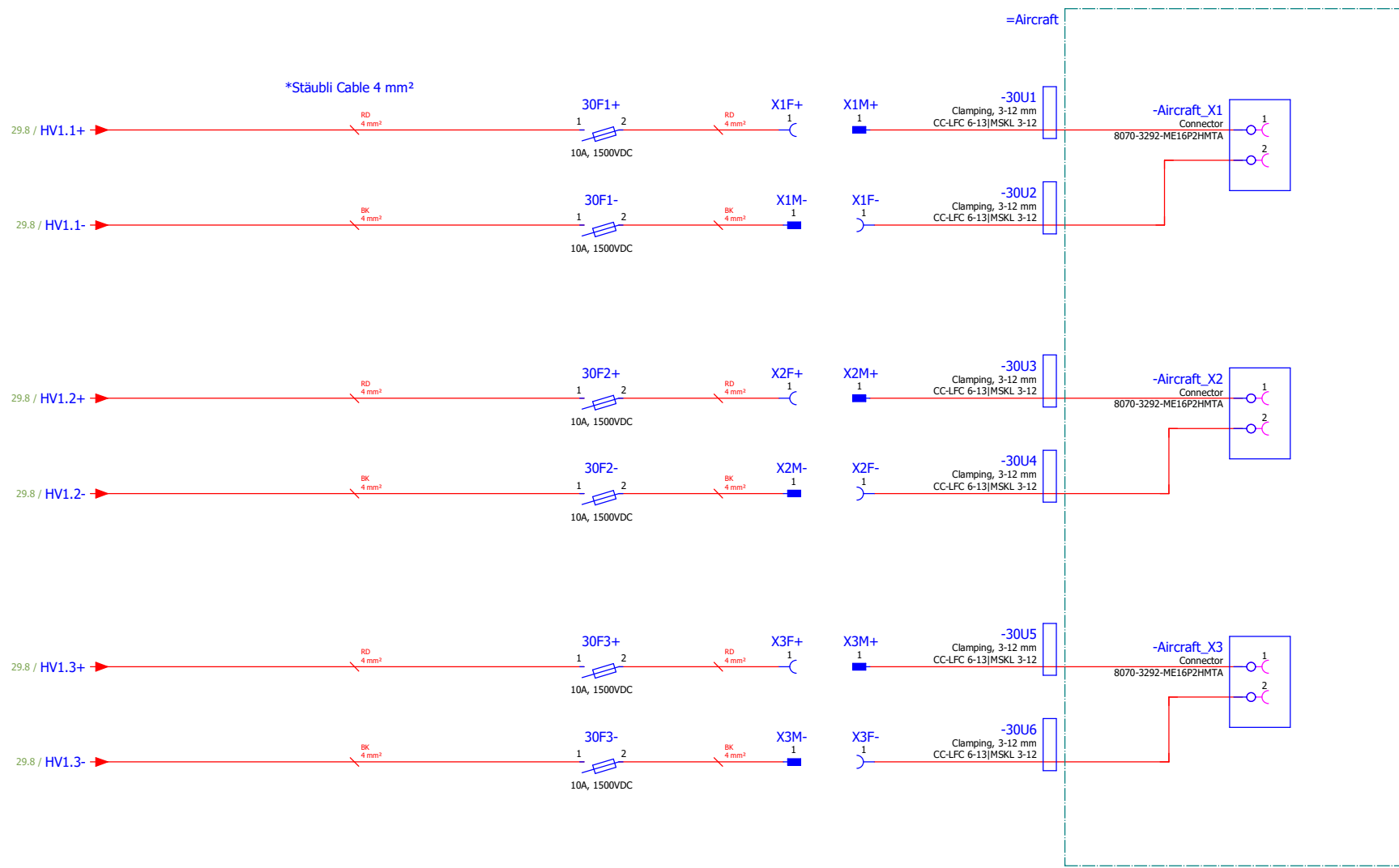

				Date	6/6/2024	ELO15 Unidirectional Power Supply & Eletronic Load Replacement of _____ Replaced by _____		Fuses & Connectors		= Main Enclosure	
				Ed.	matheus.hagemann.ext			Lilium eAircraft GmbH		+ E01	
				Appr.							
Modification	Date	Name	Original					SPDU2- / PS For MSN 1 & 2		Page	30
										Page	15 / 25

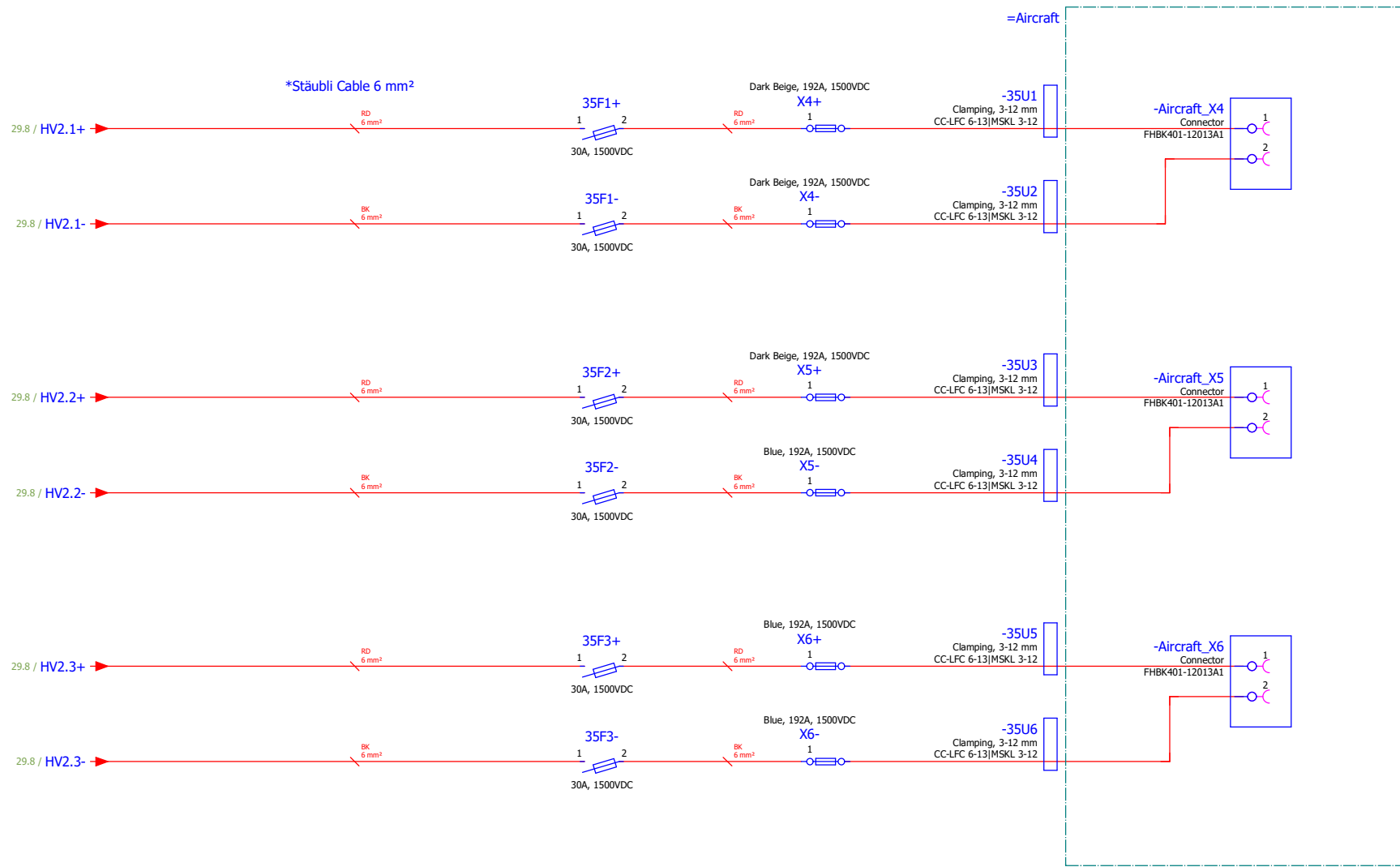

				Date	6/6/2024	EL015		Fuses & Connectors		= Main Enclosure			
				Ed.	matheus.hagemann.ext			Unidirectional Power Supply & Electronic Load		+ E01			
				Appr.				Replacement of		Replaced by			
Modification	Date	Name	Original				Lilium eAircraft GmbH		PS For MSN 1 & 2		Page 35		
											Page 16 / 25		

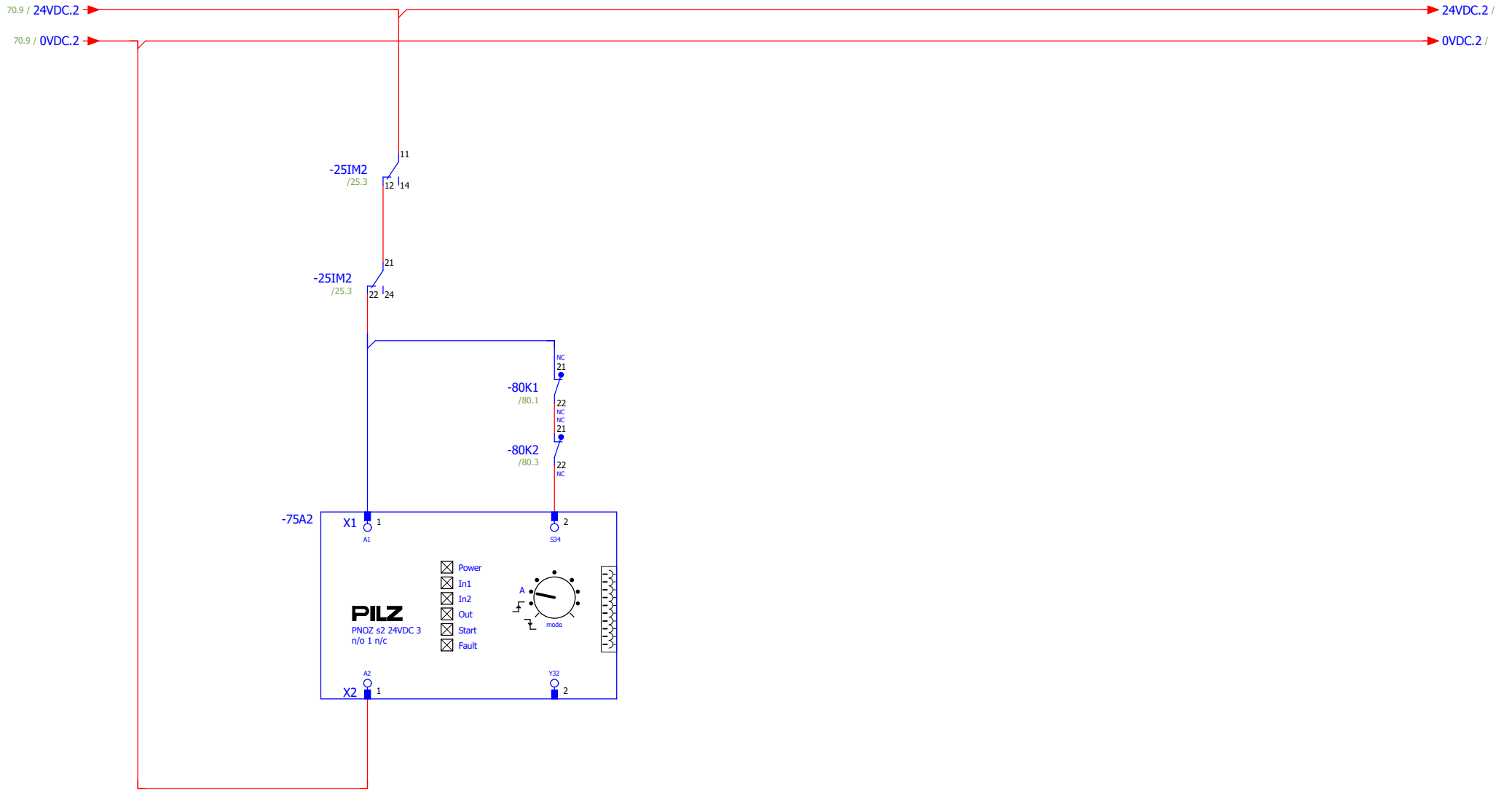

PILZ 750102
 PNOZ s2 24VDC 3 n/o 1 n/c
 13 — 14 / 80.1
 23 — 24 / 80.3
 33 — 34
 41 — 42

Set up mode: Automatic

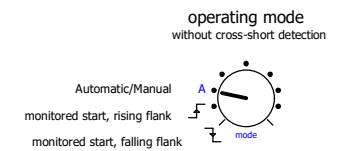

				Date	6/6/2024	EL015		Safety Relay Alarm - Insulation Monitor		= Main Enclosure	
				Ed.	matheus.hagemann.ext	Unidirectional Power Supply & Eletronic Load		Lilium eAircraft GmbH		+ E01	
				Appr.		Replacement of		Replaced by		PS For MSN 1 & 2	
Modification	Date	Name	Original								Page 75
											Page 18 / 25



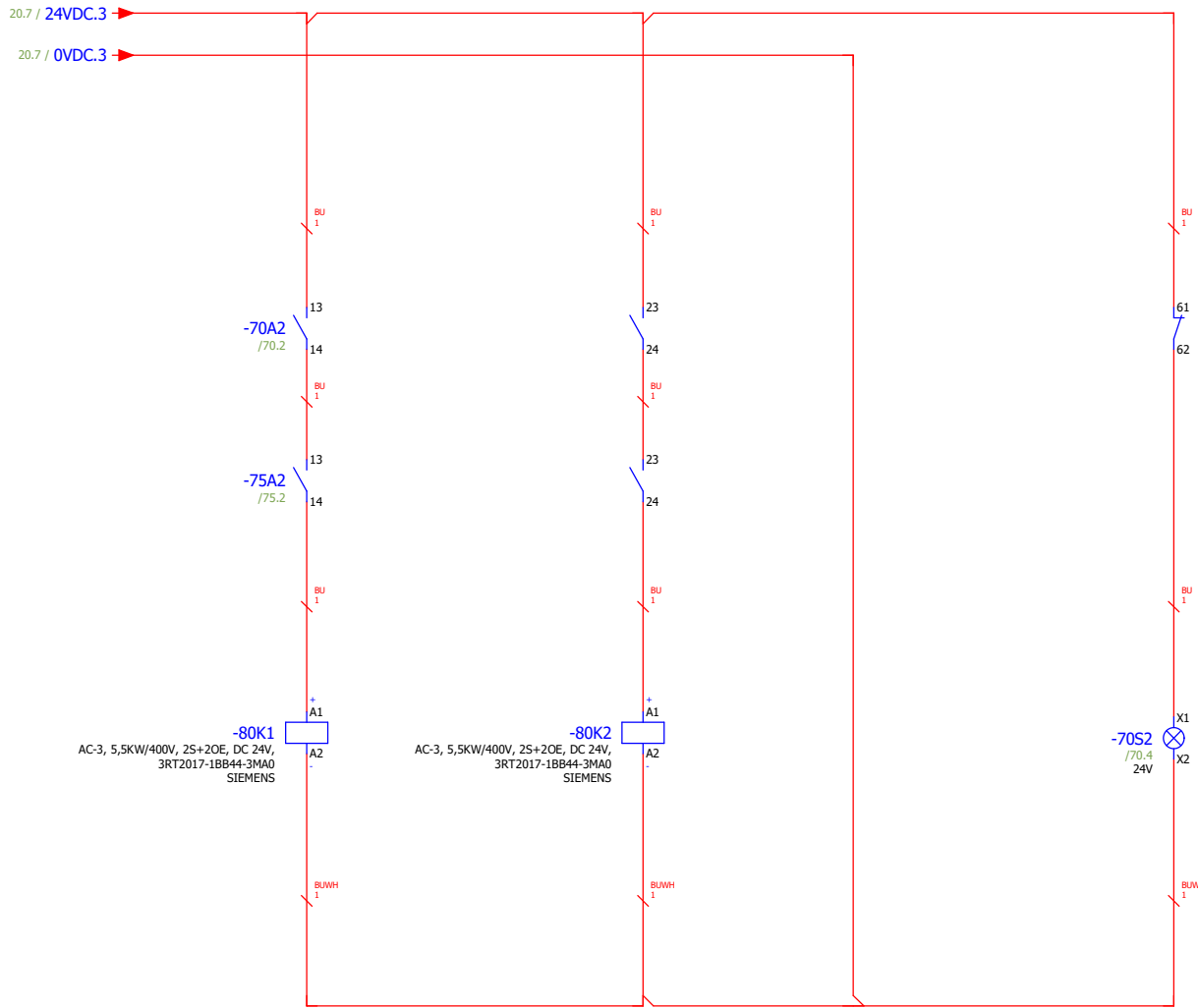

- 1/L1 ↔ 2/T1 /21.2
- 3/L2 ↔ 4/T2 /21.3
- 5/L3 ↔ 6/T3
- 13 ↔ 14
- 21 ↔ 22 /75.3
- 31 ↔ 32 /70.5
- 43 ↔ 44

- 1/L1 ↔ 2/T1 /21.2
- 3/L2 ↔ 4/T2 /21.3
- 5/L3 ↔ 6/T3
- 13 ↔ 14
- 21 ↔ 22 /75.3
- 31 ↔ 32 /70.5
- 43 ↔ 44

Modification	Date	Name	Original

Date	6/6/2024
Ed.	matheus.hagemann.ext
Appr.	
Replacement of	Replaced by



Safety Relay - Output
Lilium eAircraft GmbH

= Main Enclosure	
+ E01	
PS For MSN 1 & 2	Page 80
	Page 19 / 25

Left Side

(1x) Metallic Bracket (2mm thickness)

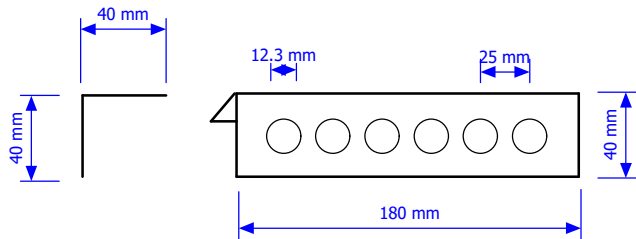

+ + + - - -

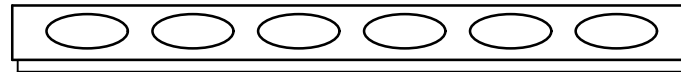

PV-ADS4-EVO 2A/2.5



PV-ADB4-EVO 2A/2.5

PV-KBT4-EVO 2A/2.5II



PV-KST4-EVO 2A/2.5II

			Date	6/6/2024
			Ed.	matheus.hagemann.ext
			Appr.	
Modification	Date	Name	Original	

EL015	
Unidirectional Power Supply & Eletronic Load	
Replacement of	Replaced by



Layout Connectors
Lilium eAircraft GmbH

= Main Enclosure	
+ E01	
PS For MSN 1 & 2	Page 901
	Page 23 / 25

