



Lilium GmbH

Claude-Dornier-Str. 1, Geb. 335
82234 Wessling
Germany



Customer	Lilium eAircraft GmbH				
Project description	Control Acquisition TRD 193				
Job number	EI_004				
Commission	Engineering / MVE				
Company name					
Project path	D:\A10 - Eplan\EL4 - TRD 193 controlling				
Project name	EL4 - TRD 193				
Power supply	0.5 KVA				
Input Voltage	24 V				
Control voltage	24 VDC				
Place of installation	Munich / Germany				
Responsible for project	Matheus				
Modification date	1/29/2021	editor	Standard	Total no. of pages	28

				Engineering / MVE		Cover		EI_004	Page name 1	
				Control Acquisition TRD 193						Page 1 / 28
Alteration	Date	Name	Origin	Replacement of	Replaced by					

Índice

Coluna X: uma página gerada automaticamente foi alterada manualmente

F06_001

Página	Descrição da página	Campo suplementar de páginas	Data	Editor	X
/1	Cover		12/14/2020	Standard	X
/2	Table of contents : /1 - /156		1/19/2021	Standard	
/5	Cable colors / General instructions		1/14/2021	Standard	X
/10	Power Distribution		1/19/2021	Standard	
/17	Distribution 24V		1/19/2021	Standard	
/18	Distribution 24V		1/19/2021	Standard	
/19	Red Led 24V		1/19/2021	Standard	
/20	Emergency Stop		1/19/2021	Standard	
/21	Emergency Stop		1/19/2021	Standard	
/25	Emergency Stop - Relay		1/19/2021	Standard	
/50	Swicht Ethernet		1/19/2021	Standard	
/55	MAINTENANCE SWITCH		1/19/2021	Standard	
/70	HVCU		1/19/2021	Standard	
/72	CAN / D SUB 15		1/19/2021	Standard	
/74	CAN / D SUB 15		1/19/2021	Standard	
/76	i-7532 CAN BUS BRIDGE		1/19/2021	Standard	
/78	DB9 - Emergency		1/19/2021	Standard	
/80	HVDU		1/19/2021	Standard	
/90	MODULE HEATERS POWER SUPPLY		1/15/2021	Standard	
/99	Hardware Presentation - General		1/12/2021	Standard	
/100	Hardware Presentation - cRIO 9047		1/19/2021	Standard	
/101	Hardware Presentation - NI 9220		1/19/2021	Standard	
/102	Hardware Presentation - NI 9213		1/14/2021	Standard	
/103	Hardware Presentation - NI 9860		1/19/2021	Standard	
/150	Schematic - NI 9220		1/19/2021	Standard	
/151	Schematic - NI 9220		1/14/2021	Standard	
/155	Schematic - NI 9213		1/14/2021	Standard	
/156	Schematic - NI 9213		1/14/2021	Standard	



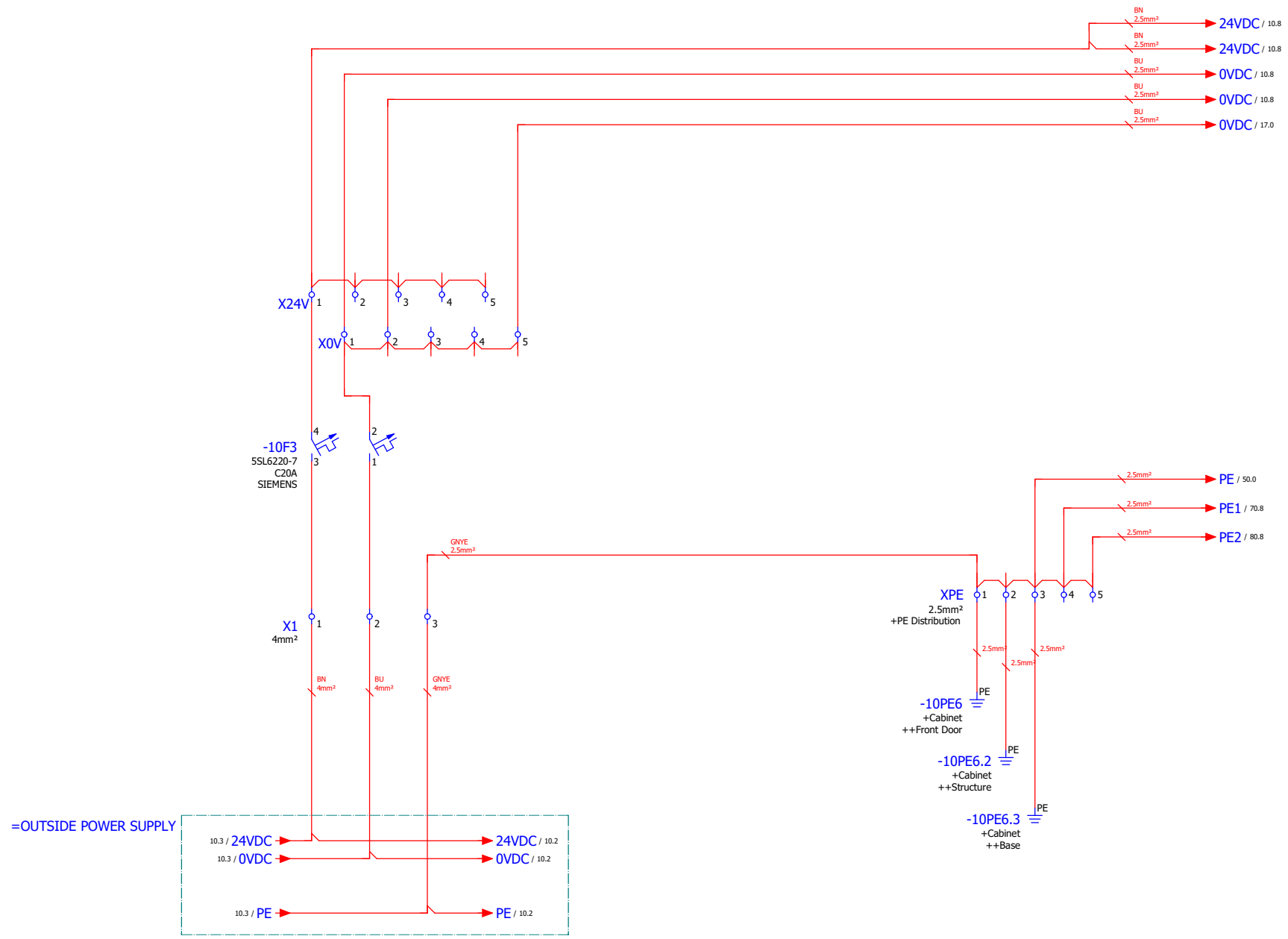

5

17

			Data	1/29/2021	Engineering / MVE			=
			Editor	Standard	Control Acquisition TRD 193			+
Alteration	Date	Name	Origin		Replacement of	Replaced by	Power Distribution	EI_004
								Page name 10
								Page 4/28



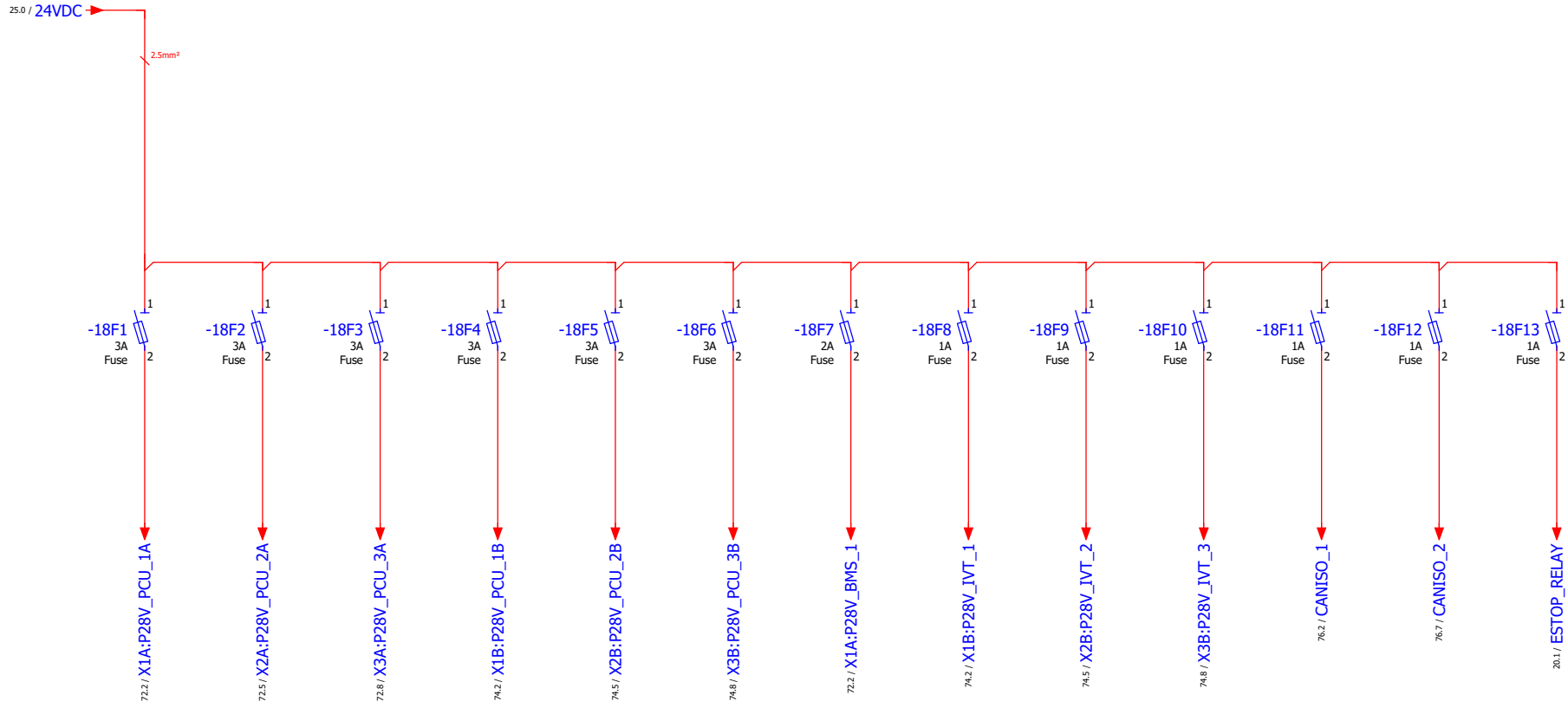

			Data	1/19/2021	Engineering / MVE			=	
			Editor	Standard	Control Acquisition TRD 193			+	
			Verif		Distribution 24V				
Alteration	Date	Name	Origin		Replacement of	Replaced by			Page name 18 Page 6/28



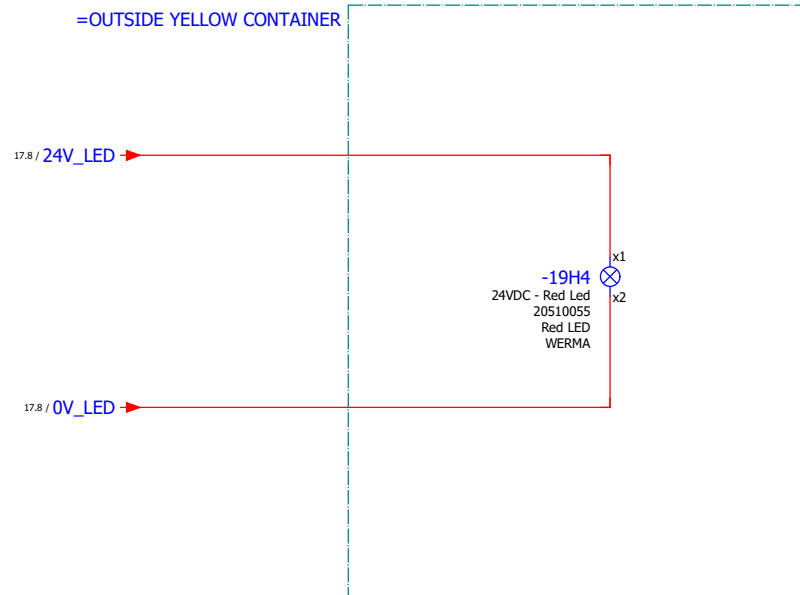

*Install outside the Yellow container.

			Data	1/19/2021	Engineering / MVE			=
			Editor	Standard				+
			Verif		Control Acquisition TRD 193			
Alteration	Date	Name	Origin		Replacement of	Red Led 24V		
					Replaced by			
							EI_004	
								Page name 19
								Page 7 / 28



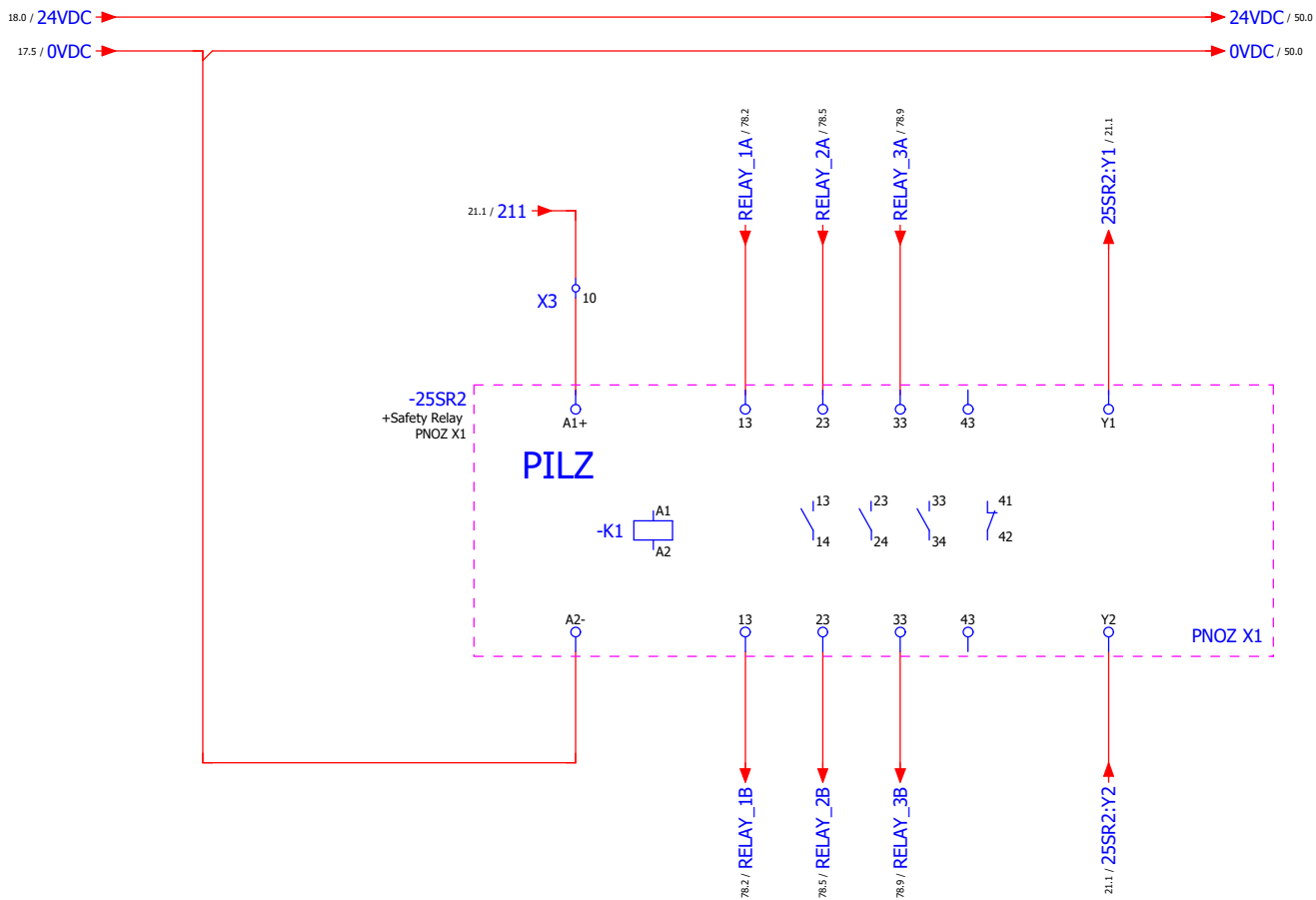

			Data	1/19/2021	Engineering / MVE			=
			Editor	Standard	Control Acquisition TRD 193			+
Alteration	Date	Name	Origin	Replacement of	Replaced by			
							EI_004	Page name 25 Page 10 / 28

=YELLOW CONTAINER
+FIELD

MODULE HEATERS POWER SUPPLY

50.2 / ETH_4

ETHERNET

—○

—○

—○

○

○

○

○

○

○

○

○

○

○

/255R2:33

			Data	1/15/2021	Engineering / MVE				=
			Editor	Standard					+
			Verif		Control Acquisition TRD 193	MODULE HEATERS POWER SUPPLY			
Alteration	Date	Name	Origin		Replacement of	Replaced by		EI_004	Page name 90 Page 19/28



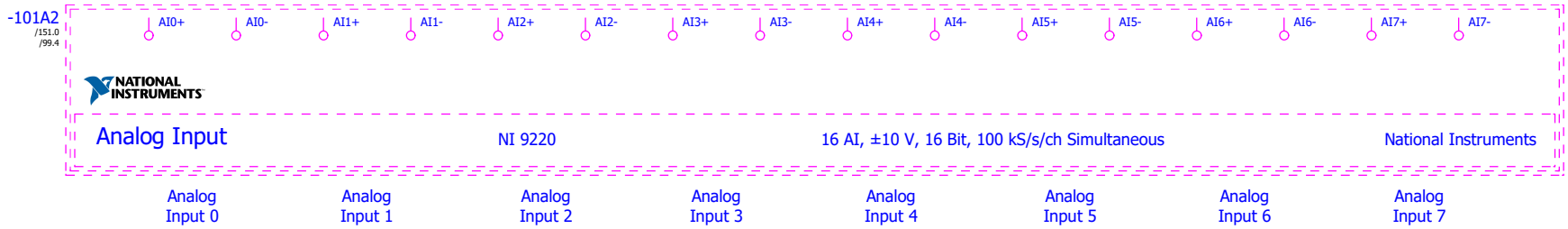

			Data	1/29/2021	Engineering / MVE	Schematic - NI 9220		E1_004	=	
			Editor	Standard	Control Acquisition TRD 193					Page name 150
			Verif		Replacement of					
Alteration	Date	Name	Origin							

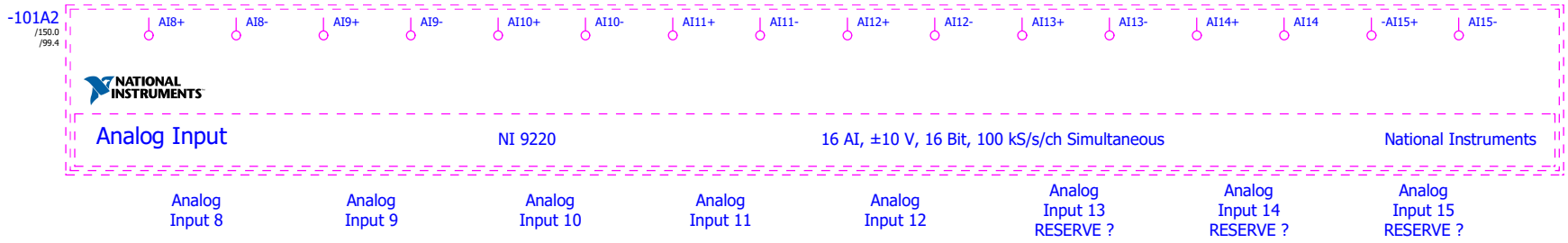

			Data	1/29/2021	Engineering / MVE	Schematic - NI 9220		E1_004	=	+	Page name 151
			Editor	Standard	Control Acquisition TRD 193						
Alteration	Date	Name	Origin	Replacement of	Replaced by						

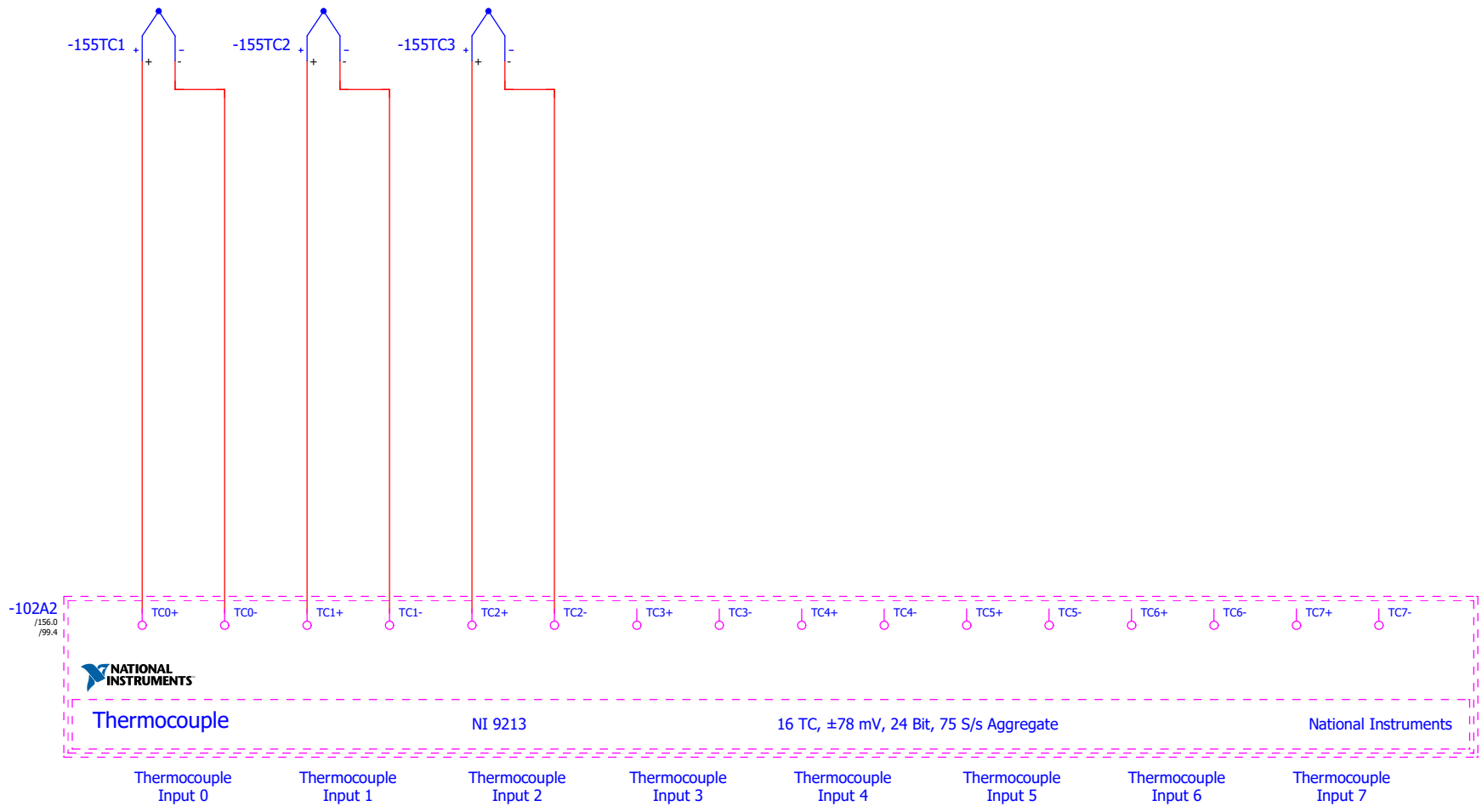

			Data	1/29/2021	Engineering / MVE			=
			Editor	Standard				+
			Verif		Control Acquisition TRD 193	Schematic - NI 9213		
Alteration	Date	Name	Origin		Replacement of	Replaced by		EI_004
								Page name 155
								Page 27 / 28



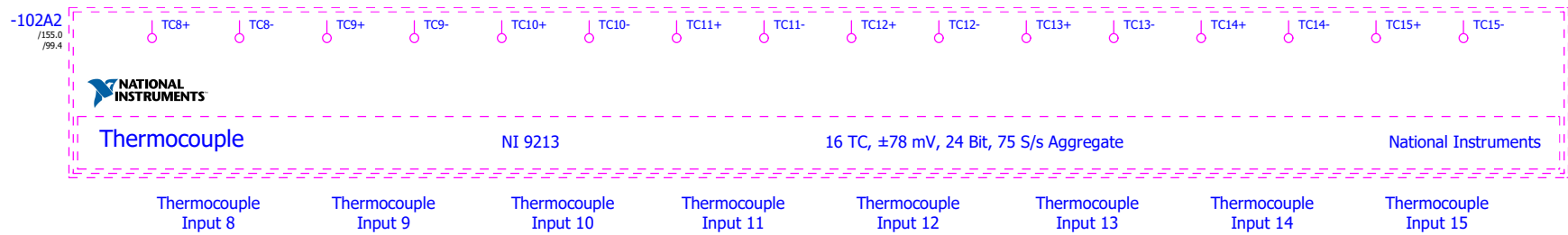

155

			Data	1/29/2021	Engineering / MVE	Schematic - NI 9213		E1_004	Page name 156
			Editor	Standard	Control Acquisition TRD 193				
Alteration	Date	Name	Origin	Replacement of	Replaced by				